



IEC/TC OR SC: 101	SECRETARIAT: Germany	DATE: 2021-09
-----------------------------	--------------------------------	-------------------------

Please ensure this form is annexed to the Report to the Standardization Management Board if it has been prepared during a meeting, or sent to the Central Office promptly after its contents have been agreed by the committee.

A. STATE TITLE AND SCOPE OF TC

Are there any new or emerging trends in technology that will impact the scope and work activities of the TC? Please describe briefly.

Do you need to update your scope to reflect new and emerging technologies? If yes, will these changes impact another TC's scope or work activities?

If yes, describe how these will impact another TC(s) and list the TC(s) it would impact

Title of TC: **ELECTROSTATICS**

TC 101 was established in January 1996 as the continuation of SC 15D created in 1990. As a result of the origins of TC 101, much of its early work was focused on the electronics industry. Whilst this is still a major part of TC 101's activities, the standards and other deliverables produced by TC 101 now cover a broad range of industries and commercial and domestic applications.

TC 101 publishes standards in the IEC 61340 series, which is divided into six parts:

- Part 1 - General;
- Part 2 - Measurement methods in electrostatics;
- Part 3 - Methods for simulating electrostatic effects;
- Part 4 - Standard test methods for specific applications;
- Part 5 - Protection of electronic devices from electrostatic phenomena;
- Part 6 - Electrostatic control in healthcare, commercial and public facilities.

TC 101 also has an input to the IEC 60079 series via Joint Working Group 29 with IEC/TC 31.

Scope

Standardisation in the field of electrostatics to provide general guidance on

- test methods to evaluate the generation, retention and dissipation of electrostatic charges;
- ascertaining the effect of electrostatic discharges;
- methods of simulation of electrostatic phenomena for testing purposes;
- requirements for design and implementation of handling areas or procedures, equipment, and materials used to reduce or eliminate electrostatic hazards or undesirable effects.

Horizontal function

Test methods to evaluate the generation, retention and dissipation of electrostatic charges.

Limitations and exclusions

The simulation of electrostatic discharges applied to powered electric and electronic equipment,

systems and installations that is covered by TC 77.

Strategic Planning Group

TC 101 has established a Strategic Planning Group (AG15) consisting of TC 101 Officers, Convenors, Project Leaders, Liaison Representatives and invited experts.

B. MANAGEMENT STRUCTURE OF THE TC

Describe the management structure of the TC (use of an organizational chart is acceptable) (should be integrated by CO automatically) and, if relevant (for example an unusual structure is used), provide the rationale as to why this structure is used.

Note: Check if the information on the IEC website is complete.

When was the last time the TC reviewed its management structure? Describe any changes made. When does the TC intend to review its current management structure? In the future, will the TC change the current structure, for example due to new and emerging technologies, product withdrawal, change in regulations etc. Please describe.

Make sure the overview includes:

- any joint working groups with other committees,
- any special groups like advisory groups, editing groups, etc.

Officers

Chairman – John T. Kinnear Jr. (US), Term of office: 2024-05

Secretary – Mr Hartmut Berndt (DE)

Technical Officer – Ms Suzanne Yap Geok Sim

Working Groups, Project Teams & Maintenance Teams

Label	Title	Convenor/Project Leader
Working Groups		
WG 5	Protection of electronic devices against static electricity	Mr Reinhold Gärtner (DE)
WG 16	Electrostatic control in healthcare, commercial and public facilities	Mr Toni Viheriäkoski (FI)
Project Teams		
PT 61340-4-2	Test methods for evaluating the electrostatic properties of garments	Dr Paul Holdstock (GB)
PT 61340-4-11	Testing of electrostatic properties of composite IBC	Mr Thilo Klein (DE)
Maintenance Teams		
MT 7	Maintenance of IEC 61340-4-4 - Electrostatics - Part 4-4: Standard test methods for specific applications - Electrostatic classification of flexible intermediate bulk containers (FIBC)	Dr Paul Holdstock (GB)
MT 8	Maintenance of IEC TR 61340-1, IEC 61340-2-1/-2/-3 and IEC TS 61340-4-2, Methods for testing static dissipative materials and surfaces	Dr Paul Holdstock (GB)
MT 9	Maintenance of IEC 61340-4-1/-3/-5 Standard test methods for specific applications - footwear and flooring	Mr Kevin Duncan (US)

MT 11	Maintenance of IEC 61340-5-3 Ed.2.0 ELECTROSTATICICS - Part 5-3: Protection of electronic devices from electrostatic phenomena - Properties and requirements classification for packaging intended for electrostatic discharge sensitive devices, and IEC 61340-4-8 Ed.2.0 ELECTROSTATICICS - Part 4-8: Standard test methods for specific applications - Electrostatic discharge shielding - Bags	Mr Rainer Pfeifle (DE)
-------	--	------------------------

Joint Working Groups

JWG 13	Packaging systems used in electronic manufacturing linked to TC 40	Mr David Swenson (US)
JWG 29	Explosive atmospheres – Electrostatic hazards. Managed by TC 31	Mr Graham Ackroyd (GB)

Strategic Planning Group

AG 15	Advisory group for strategic planning, consisting of Officers, Convenors, Project Leaders, Liaison Representatives and invited experts	John T. Kinnear Jr. (US)
-------	--	--------------------------

Liaisons

Label	Title	Liaison Representative
Internal IEC Liaison		
SC 3C	Graphical symbols for use on equipment	Mr Kevin Duncan (US)
TC 31	Equipment for explosive atmospheres	Graham Ackroyd (GB)
TC 40	Capacitors and resistors for electronic equipment	Mr David Swenson (US)
TC 44	Safety of machinery – Electrotechnical aspects	Mr Rainer Pfeifle (DE)
TC 47	Semiconductor devices	Mr Reinhold Gärtner (DE)
TC 61	Safety of household and similar electrical appliances	Mr Rainer Pfeifle (DE)
TC 62	Electrical equipment in medical practice	Mr Toni Viheriäkoski (FI)
TC 64	Electrical installations and protection against electric shock	Dr Jeremy Smallwood (GB)
TC 77	Electromagnetic compatibility	Mr John Kinnear (US)
TC 112	Evaluation and qualification of electrical insulating materials and systems	Mr Hartmut Berndt (DE)
TC 124	Wearable electronic devices and technologies	Dr Paul Holdstock (GB)
Liaisons ISO		
ISO/TC 38	Textiles	Dr Paul Holdstock (GB)
ISO/TC 45	Rubber and plastic products	Mr Kevin Duncan (US)
ISO/TC 61	Plastics	Mr Kevin Duncan (US)
ISO/TC 122/SC 3	Performance requirements and tests for means of packaging, packages and unit loads (as required by ISO/TC 122)	Dr Paul Holdstock (GB)
ISO/TC 219	Floor coverings	Dr Paul Holdstock (GB)

Review of Management Structure

The Management Structure was last reviewed, and the appointment of Convenors was confirmed during the plenary meeting of 8/9 September 2021.

The Management Structure will next be reviewed during the plenary meeting in 2022, date and place to be determined.

C. BUSINESS ENVIRONMENT

Provide the rationale for the market relevance of the future standards being produced in the TC.

If readily available, provide an indication of global or regional sales of products or services related to the TC/SC work and state the source of the data.

Specify if standards will be significantly effective for assessing regulatory compliance.

Electrostatic phenomena are in many cases unexpected and may, if undesirable, require the use of expensive preventative measures. They arise primarily because of the charge retention properties of insulating materials. If electrostatic phenomena are neglected then electronic devices can be damaged, unsuspecting people can be distracted or otherwise unsettled, and the risk of explosions in flammable atmospheres can be increased. The extent of electrostatic effects depends not only on the nature of materials or the construction of devices, but also on the environment and the expertise and training of the persons who handle those materials or devices.

Electrostatic phenomena arise in many circumstances, environments and industries. Common examples include:

- the electronics industry, including end users of electronic systems, where small electrostatic discharges can damage or disrupt sensitive electronic components and systems during manufacturing, storage, transportation and use, and where electrostatic attraction and repulsion can cause problems when packing, unpacking or placing small surface mount devices (SMD) on circuit boards;
- process industries, e.g. petrochemical, chemical, pharmaceutical, printing and finishing, where the generation of static electricity can give rise to electrostatic discharges capable of igniting flammable gases, vapours and dusts, and where electrostatic attraction or repulsion can cause lightweight materials to mis-feed through process machinery;
- healthcare facilities and cleanroom environments where electrostatic attraction and repulsion of fine particle can cause contamination issues;
- domestic, retail, office and other environments where the interaction of personnel with flooring and furnishing materials can lead to personnel experiencing shocks.

Static electricity can be also used in applications (e.g. electrostatic spray painting and separation). The development of standards for such applications is not currently part of the TC 101 work programme, but there may be demand in future.

The control of electrostatic phenomena requires a good understanding of the causes of problems. Standards that merely prescribe design and construction principles are in most cases not sufficiently helpful because unintentional changes in peripheral conditions can reduce the benefit of preventative measures taken. Therefore, electrostatic experience is often described in the form of Technical Reports, which support Standards and Technical Specifications.

D. MARKET DEMAND

Provide a list of likely customers of the standards (suppliers, specifiers, testing bodies, regulators, installers, other TC/SC's etc.). Do not specify company names, only categories of customers.

Electronics Sector

All electronic components and assemblies are at some risk from electrostatic discharges (ESD). All active electronic components, beginning with simple diodes, transistors or complex inner circuits, require an external ESD control programme. Surface mount devices, resistors and condensers, and prospectively micro and nano electro-mechanical systems are also at significant

risk of damage or disruption caused by exposure the electrostatic fields or ESD.

The number of failures caused by ESD has been increasing for some time now. So, it is necessary for everyone who handles ESD sensitive devices, during manufacture or use, to understand the reasons for such failures and how to employ the necessary measures to prevent failures from occurring.

Device and system susceptibility is determined by exposure to simulated ESD events. Standards are required for the simulation of a number of ESD events, including Human Body Model (HBM) and Charged Device Model (CDM), and other new models. Standards and Technical Reports are required to give guidance on the design and implementation of ESD control programmes and for the evaluation of materials and ESD control items.

The keystone standard for protection of electronic devices from electrostatic phenomena is IEC 61340-5-1, which is supported by a user guide, IEC/TR 61340-5-2. Other standards within the IEC 61340 series provide standard test methods used for qualification and compliance verification of the equipment and materials specified in IEC 61340-5-1.

Customers for IEC 61340 series standards for protection of electronic devices from electrostatic phenomena are individuals, companies and organisations that handle, transport or store ESD sensitive devices and systems, or are otherwise responsible for ensuring the protection of electronic devices and systems, including:

- manufacturers, distributors, suppliers and users of electronic components and equipment and systems that use electronic components;
- manufacturers, distributors, suppliers and users of materials and equipment used to control static electricity in ESD protected areas (EPA);
- testing laboratories responsible for determining the susceptibility of devices and systems to damage or disruption by electrostatics phenomena;
- test laboratories responsible for the qualification of materials and equipment used to control static electricity in ESD protected areas (EPA);
- auditors responsible for verifying compliance with ESD control programmes.

IEC 61340 series standards are used by individuals and small to medium sized enterprises (SME), where there is a requirement for clear guidance on establishing cost effective ESD control programmes. Large enterprises, including multi-national companies, also use IEC 61340 series standards to ensure consistency of protection throughout multiple manufacturing operations, often dispersed around the world.

IEC 61340 series standards provide a world-wide recognised basis for evaluation of ESD protection and are used as a means of establishing best practice ESD control programmes. To avoid competition from the American ESD Association (ESDA) standards, TC 101 has established cooperation with ESDA to ensure a good degree of harmonisation between the standards published by both organisations.

Occupational & Process Safety

Increased automation in modern industrial operations, combined with a greater understanding of explosion hazards has created a demand for a more systematic approach to process safety in industrial operations involving potentially explosive atmospheres.

The IECEx System and other national and international Conformity Assessment Systems, such as those covered by the ATEX Directives in Europe, have been established to ensure an internationally uniform approach to safety assessment and certification. Electrostatic discharges are a known source of ignition, capable of igniting gases and vapours and thin layers or clouds of dust. Controlling static electricity is an important part of process safety and standards for measuring and controlling static electricity and for evaluating static control materials and products are a vital part of any Conformity Assessment System.

IEC 61340 series standards provide standard test methods for general application and product specific application that may be used to evaluate static protective materials and products, including footwear, flooring, work surfaces, clothing and other items of personal protective equipment (PPE), containers, earthing/grounding systems, etc.

As a result of industry demand from end users and manufacturers, TC 101 established a Joint Working Group (JWG 7) with ISO/TC 122/SC 3 to develop a product safety standard for static protective flexible intermediate bulk containers (FIBC). The first edition of the standard was published as a dual logo standard IEC/ISO 61340-4-4. TC 101 now has sole responsibility for maintenance and subsequent editions will be published as IEC 61340-4-4 (single logo). A similar standard for composite intermediate bulk containers (IEC 61340-4-11) is in development by TC 101 with liaison co-operation with ISO/TC 122/SC 3.

TC 101 has also established a Joint Working Group (JWG 29) with IEC/TC 31- Electrical Equipment for Explosive Atmospheres, to develop guidance for the avoidance of hazards caused by static electricity in hazardous explosive environments, and test methods for evaluating electrostatic control materials, equipment and systems. The standards will be published in the IEC 60079 series. The main guidance and test method standards will be published in Part 32, and additional guidance and test methods will be published in other parts of IEC 60079 as appropriate. Such guidance and test method standards are essential for the full implementation of ATEX Directive in Europe and the IECEx system internationally.

Customers for IEC 61340 series and IEC 60079 series standards are individuals, companies and organisations that manufacturer, process, transport or store flammable or explosive substances, or are otherwise responsible for ensuring the prevention of fires and explosions, including:

- standards organisations responsible for supporting national and international regulations and directives for occupational and process safety (e.g. IECEx, ATEX Directives, PPE Directives, etc.)
- manufacturers, distributors, suppliers and users of flammable solvents, gases, materials that form combustible dusts, explosives and pyrotechnic articles;
- manufacturers, distributors, suppliers and users of materials and equipment used to control static electricity in hazardous areas;
- test laboratories responsible for the qualification of materials and equipment used to control static electricity in hazardous areas;
- auditors responsible for verifying compliance with process safety regulations and directives (ATEX, IECEx, etc.).

IEC 61340 series and IEC 60079 series standards are used by individuals and small to medium sized enterprises (SME), where there is a requirement for clear guidance on establishing cost effective electrostatic hazard prevention programmes. Large enterprises, including multi-national companies, also use IEC 61340 series and IEC 60079 series standards to ensure consistency of approach throughout multiple manufacturing operations, often dispersed around the world.

Electrostatic Nuisance & Other Phenomena

IEC 61340 series and IEC 60079 series standards have broad application in the specification, testing and qualification of materials and products used to control electrostatic nuisance and other phenomena.

Nuisance phenomena include:

- electrostatic shocks;
- electrostatic clinging of lightweight materials (e.g. clothes clinging);
- electrostatic attraction of dust causing undesirable aesthetic appearance of products.

Other electrostatic phenomena can have more serious consequences:

- some electrostatic shocks can be quite severe, and even though they are rarely directly harmful, the physiological reaction can cause people to have other accidents;
- electrostatic repulsion (e.g. yarn ballooning, uneven dispersal of powder coatings, etc.) leading to loss of production efficiency;
- electrostatic attraction and repulsion of fine particles causing contamination problems, which may have a detrimental impact on human health.

The potential customer base for such applications of IEC 61340 series standards is vast, and includes, for example:

- domestic (floor coverings, furnishings);
- commercial (offices, shops, airports);
- healthcare (hospital wards, operating theatres);
- industrial (cleanrooms, manufacturing, processing).

E. SUSTAINABILITY DEVELOPMENT GOALS

INDICATE THE SUSTAINABLE DEVELOPMENT GOALS (SDGs) THAT ARE ADDRESSED BY WORK WITHIN THE TC/SC. INDICATE EACH SDG INDICATOR AFFECTED (REFERENCE SPREADSHEET AVAILABLE AT <https://www.iec.ch/SDG/>), AND PROVIDE SPECIFIC INFORMATION ABOUT HOW THE TC/SC IS ADDRESSING THE SDG. CONSIDER BOTH DIRECT AND INDIRECT IMPACTS OF THE WORK OF THE TC/SC.

<input checked="" type="checkbox"/> GOAL 1: No Poverty	<input checked="" type="checkbox"/> GOAL 10: Reduced Inequality
<input checked="" type="checkbox"/> GOAL 2: Zero Hunger	<input checked="" type="checkbox"/> GOAL 11: Sustainable Cities and Communities
<input checked="" type="checkbox"/> GOAL 3: Good Health and Well-being	<input checked="" type="checkbox"/> GOAL 12: Responsible Consumption & Production
<input checked="" type="checkbox"/> GOAL 4: Quality Education	<input checked="" type="checkbox"/> GOAL 13: Climate Action
<input checked="" type="checkbox"/> GOAL 5: Gender Equality	<input checked="" type="checkbox"/> GOAL 14: Life Below Water
<input checked="" type="checkbox"/> GOAL 6: Clean Water and Sanitation	<input checked="" type="checkbox"/> GOAL 15: Life on Land
<input checked="" type="checkbox"/> GOAL 7: Affordable and Clean Energy	<input checked="" type="checkbox"/> GOAL 16: Peace, Justice Strong Institutions
<input checked="" type="checkbox"/> GOAL 8: Decent Work & Economic Growth	<input checked="" type="checkbox"/> GOAL 17: Partnerships to achieve the Goals
<input checked="" type="checkbox"/> GOAL 9: Industry, Innovation & Infrastructure	

GOALS 1 TO 17

IEC 61340-5-1 specifies requirements for electrostatic control in activities that manufacture, process, assemble, install, package, label, service, test, inspect, transport or otherwise handle electrical or electronic component parts of hardware such as computers, routers, video, radio, mobile phones, sensors, control and monitoring equipment, artificial intelligence, smart systems and other enabling technologies that directly or indirectly support all 17 SDG. The standard is supported by the following publications:

IEC TR 61340-1, IEC 61340-2-1, IEC TS 61340-2-2, IEC 61340-2-3, IEC 61340-4-1, IEC TS 61340-4-2, IEC 61340-4-3, IEC 61340-4-5, IEC 61340-4-6, IEC 61340-4-7, IEC 61340-4-8, IEC 61340-4-9, IEC TR 61340-5-2, IEC 61340-5-3, IEC TS 61340-5-4, IEC TR 61340-5-5, ISO 18080-2*, ISO 18080-3*, ISO 18080-4*

*Developed jointly by ISO/TC 38 and ISO/TC 101.

PWI TS 101-3 ED 1 will specify requirements and recommendations for characterising processes where ESD sensitive (ESDS) items are handled, which includes the manufacturing of electrical or electronic hardware, and component parts thereof, such as computers, routers, video, radio, mobile phones, sensors, control and monitoring equipment, artificial intelligence, smart systems and other enabling technologies that directly or indirectly support all 17 SDG.

PWI TS 101-4 ED 1 will provide guidance, recommendations and requirements for controlling the following electrostatic risks in commercial and public facilities (SDG goals supported directly or indirectly by this project are shown in parentheses):

- a. electrostatic shocks to people (**GOAL 3**);
- b. electromagnetic interference (EMI) or electrostatic discharge (ESD) disruption or damage to electronic equipment, audiovisual systems, computers and mobile devices such as telephones, tablets computers, and laptops computers, etc. (**GOALS 1 TO 17**);
- c. contamination (including microbial contamination) caused by electrostatic attraction and repulsion (**GOAL 3**);
- d. ignition of flammable gases, liquids and other materials (**GOAL 8**).

GOAL 1: NO POVERTY, GOAL 2: ZERO HUNGER & GOAL 8: DECENT WORK & ECONOMIC GROWTH

IEC 61340-4-4 specifies electrostatic safety requirements for FIBC, which are the most cost-effective packaging and transport unit load system. FIBC can be used for food and agricultural products, and are particularly important for small-scale farms and food production. Safety requirements contribute to promoting safe and secure working environments.

GOAL 3: GOOD HEALTH AND WELL-BEING

IEC 61340-6-1 specifies requirements for electrostatic control in healthcare facilities. The standard is supported by the following publications:

IEC TR 61340-1, IEC 61340-2-1, IEC TR 61340-2-2, IEC 61340-2-3, IEC 61340-4-1, IEC TS 61340-4-2, IEC 61340-4-3, IEC 61340-4-5, IEC 61340-5-1, ISO 18080-2*, ISO 18080-3*, ISO 18080-4*

*Developed jointly by ISO/TC 38 and ISO/TC 101.

F. TRENDS IN TECHNOLOGY AND IN THE MARKET

If any, indicate the current or expected trends in the technology or in the market covered by the products of your TC/SC.

TRENDS IN TECHNOLOGY

Electronics Sector

Internal structure sizes of electronic components continue to become smaller. Already 5 volts human body model electrostatic discharges are enough to cause undesirable changes in the structure and operation of some electronic components. By the year 2024, the size of the smallest electronic structures will be less than 10 nm. Electrostatic charges of 0,1 nC and electrostatic fields of 1000 V/m will be enough to damage such electrostatic discharge sensitive devices permanently. ESD control programme guidelines and requirements in IEC 61340 series standards are based on manual assembly techniques and components with ESD sensitivity of 100V HBM, 200 V CDM and 35 V on isolated conductors. The following trends will require re-evaluation of the current IEC 61340 series of standards and possibly the development of new standards:

- the dimensions of some devices are decreasing, whereas for other devices, dimensions are increasing and incorporating many more internal structures and many hundreds of connection pins;
- the use of surface mount technologies with high component densities is becoming increasingly common-place;
- handling of sub-100V HBM components is already becoming common;
- on-chip ESD protection is gradually being reduced as ESD protection in assembly becomes more capable and is widely used;
- a large proportion of electronics systems now have some element of automated handling and assembly; protection against Charged Device Model ESD and Charged Board events, is now required for automated handling equipment;
- ESD protective packaging for small devices has very small features which are not measureable using current methods;
- the types of ESD protective packaging are diversifying.

Occupational & Process Safety

There are a number of trends that impact on the risks associated with static electricity in industrial operations:

- increased use of engineering plastics, many of which are electrically insulating;
- increased automation and process efficiency resulting in faster operation, which can mean higher electrostatic charging currents;
- the switch from coal, oil and petroleum to gas (natural gas, LPG, hydrogen, etc.) as fuels creates an increased risk because ignition energies tend to be lower;
- the use of biofuels containing ethanol increases risk because their vapours often exist within flammable limits under normal conditions;
- new methods of packaging and transporting flammable materials often involve use of plastic insulating materials – e.g. fuel pipes used in forecourts, rigid intermediate bulk containers used to transport of liquids, etc.

Electrostatic Nuisance & Other Phenomena

Polymeric materials (plastics, resins, etc.), which can readily acquire and retain electrostatic charge, are being used increasingly for flooring and furnishing applications for a number of reasons: lack of availability of sustainable natural products (wood, stone, etc.), ease of cleaning and sterilisation, cost, durability, aesthetics, etc.

MARKET TRENDS

Electronics Sector

There continues to be an increasing demand for consumer, commercial and industrial electronics

in developed and developing countries throughout the world. The number of SME in the electronics industry is growing as new companies are established to exploit new technology. Large multi-national corporations are outsourcing manufacturing to smaller enterprises, to take advantage of lower labour and production costs and to bring manufacturing closer to consumers.

Healthcare Sector

When the regular use of flammable anaesthetics was discontinued in most healthcare facilities, the requirements for electrostatic control were largely relaxed. Consequently, many new facilities do not have any form of electrostatic control. The consequence of this is that reports of electrostatic problems in healthcare facilities are increasing. The re-establishment of electrostatic controls within the healthcare infrastructure is becoming a priority concern in many countries.

There is increased focus on infection control and all technologies and procedures that can improve our ability to minimise the transmission of infectious diseases, particularly in healthcare environments. Research has shown that the use of some non-static dissipative personal protective equipment (PPE) can increase the deposition of airborne pathogens on to patients. On-going research might confirm that these findings can be extended to other items of PPE and other materials (e.g. bedding, furnishing, etc.). In 2018, TC 101 published a standard, IEC 61340-6-1, for electrostatic control in healthcare facilities, which identifies contamination caused by electrostatic attraction as one of the electrostatic risks that needs to be controlled. Following more research, it might become necessary to develop a comprehensive standard specifically for electrostatic aspects of infection control that might include requirements for materials and control systems (e.g. ionizers, vertical potential gradients).

Other Sectors

As in the electronics sector, production within other sectors of industry is being increasingly outsourced to smaller, local enterprises. It is these smaller, and often newer, companies that are most in need of guidance and instruction provided by International Standards. Technological developments drive market trends. For example, the demand for biofuels has encouraged companies that have traditionally only been involved in agriculture to expand their operations into the production of biofuels. Such companies may not have the extensive background knowledge of process safety that exists in the traditional petrochemical industry.

There is increasing awareness that shocks and exposure to electrostatic fields and low-level electrostatic discharges might have an impact on people's health. Whereas control of static electricity is common in some industrial sectors (e.g. electronics, chemical processing, etc.), it has until now been less common in other industrial sectors, and in commercial and domestic environments. With a general trend in society to be more cognisant of the need to protect human health both at home and at work, and the increased willingness to seek financial compensation for any workplace injuries, there is an impetus to introduce controls on static electricity in areas where such controls have not previously existed or have been ignored.

G. SYSTEM APPROACH ASPECTS (REFERENCE - AC/33/2013)

Does your TC/SC have a need for a systems approach?

If so:

- Will the Systems work be in a single TC or in multiple TCs?
- Will a Systems Evaluation Group (SEG), Systems Committee (SyC), or Systems Resource Group be required?
- Is your TC/SC work of relevance to ISO?
- Is or are there fora or consortia working in parallel to IEC? Is there a chance to integrate this work in your TC/SC?

This should not only be restricted to the customer/supplier relationships with other TC/SCs indicating types of co-operation (e.g. liaisons, joint working groups) but be of a more generic nature.

If there is no need for a systems approach as outlined in AC/33/2013, is it intended a TC would not be requested to report on general systems approach considerations such as customer/supplier relationships, liaisons, joint WGs, etc. as referenced in the system approach matrix illustrated in slide 14 of the presentation attached to AC/37/2006?

TC 101 continuously reviews liaison with other TC within IEC, ISO and other standards organisations, and establishes new liaison arrangements when required. The customer/supplier relationships (outputs/inputs) and liaison arrangements with other TC, SC and WG are shown in Figure 1.

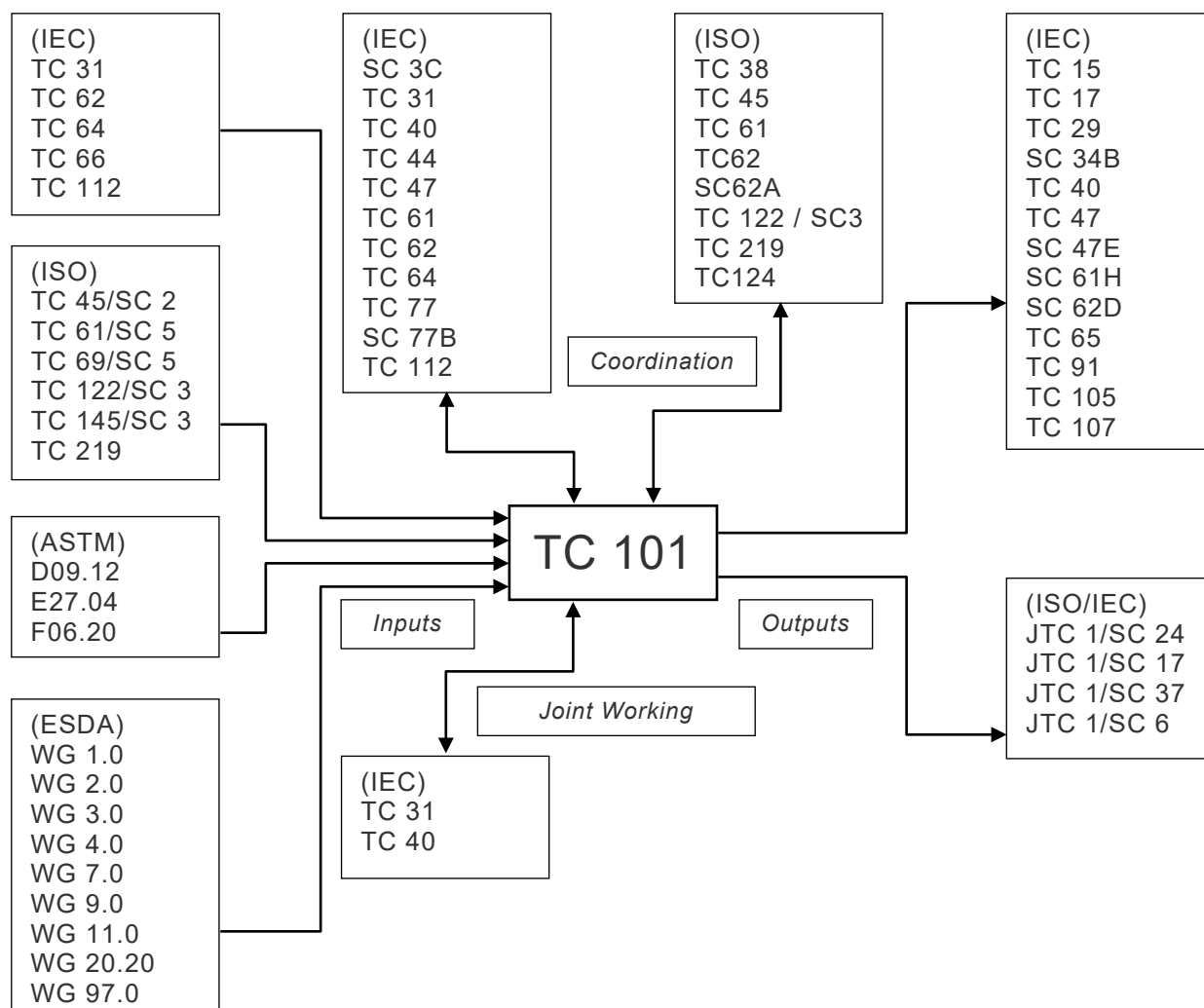

Figure 1. TC 101 system approach to standardisation.

IEC Technical Committees/Sub-Committees

SC 3C:	Graphical symbols for use on equipment
TC 15:	Solid electrical insulating materials
TC 17:	High-voltage switchgear and controlgear
TC 29:	Electroacoustics
TC 31:	Equipment for explosive atmospheres
SC 34B:	Lamp caps and holders
TC 40:	Capacitors and resistors for electronic equipment
TC 44:	Safety of machinery - Electrotechnical aspects
TC 47:	Semiconductor devices
SC 47E:	Discrete semiconductor devices
TC 61:	Safety of household and similar electrical appliances
SC 61H:	Safety of electrically-operated farm appliances
TC 62:	Electrical equipment in medical practice
SC 62A:	Common aspects of electrical equipment used in medical practice
SC 62D:	Electromedical equipment
TC 64:	Electrical installations and protection against electric shock
TC 65:	Industrial-process measurement, control and automation
TC 66:	Safety of measuring, control and laboratory equipment
TC 77:	Electromagnetic compatibility

SC 77B: High frequency phenomena
 TC 91: Electronics assembly technology
 TC 105: Fuel cell technologies
 TC 107: Process management for avionics
 TC 112: Evaluation and qualification of electrical insulating materials and systems
 TC 124: Wearable electronic devices and technologies

ISO Technical Committees/Sub-Committees

TC 38: Textiles
 TC 45: Rubber and rubber products
 TC 45/SC 2: Testing and analysis
 TC 61: Plastics
 TC 61/SC 5: Physical-chemical properties
 TC 69: Applications of statistical methods
 TC 69/SC 5: Acceptance sampling
 TC 122: Packaging
 TC 122/SC 3: Performance requirements and tests for means of packaging, packages and unit loads (as required by ISO/TC 122)
 TC 145: Graphical symbols
 TC 145/SC 3: Graphical symbols for use on equipment
 TC 219: Floor coverings

ISO/IEC Joint Technical Committees/Sub-Committees

JTC 1: Information technology
 JTC 1/SC 6: Telecommunications and information exchange between systems
 JTC 1/SC 17: Cards and security devices for personal identification
 JTC 1/SC 24: Computer graphics and image processing
 JTC 1/SC 37: Biometrics

ASTM Technical Committees/Sub-Committees

D09: Electrical and electronic insulating materials
 D09.12: Electrical tests
 E27: Hazard potential of chemicals
 E27.04: Flammability and ignitability of chemicals
 F06: Resilient floor coverings
 F06.20: Test methods - Products construction/materials

ESD Association Working Groups

WG 1.0: Wrist straps
 WG 2.0: Garments
 WG 3.0: Ionization
 WG 4.0: Work surfaces
 WG 7.0: Flooring
 WG 9.0: Footwear
 WG 11.0: Packaging
 WG 13: Handtools, soldering and de-soldering equipment
 WG 15: Gloves
 WG 17: Process assessment
 WG 20.20: ESD Control Program
 WG 97.0: Footwear and Flooring Systems

H. CONFORMITY ASSESSMENT

With reference to clause 6.7 of Part 2 of the ISO/IEC directives, are all your publications in line with the requirements related to conformity assessment aspects?

Will the TC/SC publications be used for IEC Conformity Assessment Systems (IECEE, IECEx, IECQ, IECRE)?

Will any of your standards include test specifications, reproducible test requirements, and test methods?

Are there likely to be special conformity assessment requirements generated by any standards projects? If yes, list which projects.

The following documents contain test specifications, requirements and test methods that can be

used by IECEx:

IEC TS 60079-32-1 (developed joint with TC 31)

IEC 61340-4-4 (developed jointly with ISO/TC 122/SC 3)

The following documents contain test methods that can be used by IECEx:

IEC 60079-32-2 (developed jointly with TC 31)

IEC 61340-2-1

IEC 61340-2-3

IEC 61340-4-1

IEC 61340-4-3

IEC 61340-4-4

IEC 61340-4-5

I. HORIZONTAL ISSUES

When TC 101 was first established, it was assigned a Horizontal Safety Function (HSF), the scope of which was to specify methods of test and relevant equipment to evaluate generation, retention and dissipation of electrostatic charges on materials. However, on the advice of ACOS, the HSF was withdrawn in 2016 because at that time the test method standards developed by TC 101 did not comply with any of the safety publications defined by ACOS.

The new category of safety publication being considered by ACOS, safety test method publications, is intended for publications that are used exclusively for safety testing. Although some of the test methods developed by TC 101 can be used for safety testing, they all have wider application and are not intended exclusively for safety testing. At this time, TC 101 does not require a HSF,

TC 101 has developed one horizontal standard in accordance with IEC Guide 108: IEC 61340-2-1:2015 Electrostatics - Part 2-1: Measurement methods - Ability of materials and products to dissipate static electric charge.

J. 3-5 YEAR PROJECTED STRATEGIC OBJECTIVES, ACTIONS, TARGET DATES

STRATEGIC OBJECTIVES 3-5 YEARS	ACTIONS TO SUPPORT THE STRATEGIC OBJECTIVES	TARGET DATE(S) TO COMPLETE THE ACTIONS
<p>General Guidance</p> <p>TC 101 has published a guidance document on electrostatic phenomena that has wide application and is intended to serve as a reference for the development of electrostatics related standards, and to provide guidance for their end-users. This document will be updated to reflect developments in industry and other standards.</p>	<p>Revisions</p>	<p>Published (2020-06-10)</p>
	<p>IEC TR 61340-1/AMD1 ED1 Electrostatics - Part 1: Electrostatic phenomena - Principles and measurements</p>	
<p>Electronics Sector</p> <p>TC 101 will systematically review IEC 61340 Part 5 standards and other supporting standards in the IEC 61340 series to maintain their relevance with respect to developments in the electronics industry.</p> <p>Standards will be updated and new guidance and test method standards will be added to include:</p> <ul style="list-style-type: none"> • electrostatic control in healthcare; • compliance verification; • ESD protective packaging; • automated handling equipment and systems; • sub-100V HBM ESD protection. 	<p>New Projects</p>	
	<p>IEC TS 61340-5-4 Electrostatics – Part 5-4: Protection of electronic devices from electrostatic phenomena – Compliance verification</p>	<p>Published (2021-08)</p>
	<p>PWI/TS 101-3 Technical Specification on Process assessment</p> <p>(ANSI/ESD SP17.1-2020 to be submitted as PAS to address immediate market need)</p>	<p>Submit TS 2021-12</p>
	<p>Revisions</p>	
	<p>IEC 61340-5-1 Electrostatics - Part 5-1: Protection of electronic devices from electrostatic phenomena - General requirements</p>	<p>Revision to start 2022-12</p>
	<p>IEC TR 61340-5-2 Electrostatics - Part 5-2: Protection of electronic devices from electrostatic phenomena - User guide</p>	<p>To be reviewed in 2022-06</p>
	<p>Electrostatics - Part 5-3 ED3: Protection of electronic devices from electrostatic phenomena - Properties and requirements classification for packaging intended for electrostatic discharge sensitive devices</p>	<p>Edition 3 to be published 2022-01 (need new target date for publication)</p>
	<p>IEC 61340-2-1/AMD1 ED2: Measurement methods - Ability of materials and products to</p>	<p>Publish 2022-11</p>

	dissipate static electric charge	
	IEC 61340-4-6/AMD1 ED2: Standard test methods for specific applications - Wrist straps	Publish 2022-09
	IEC 61340-4-7 ED3: Standard test methods for specific applications - Ionization	Publish 2022-09
	IEC 61340-4-9 ED3: Standard test methods for specific applications - Garments	Publish 2022-09
	Withdrawals	
	IEC 61340-3-1 and IEC 61340-3-2 (covered by other standards in the IEC 60749 series from TC 47, the stability has been revised to 2020 to allow normative references in other standards to be changed to the corresponding standard in the IEC 60749 series)	Withdrawn 2020-12
<p>Occupational & Process Safety</p> <p>TC 101 will continue to work with TC 31 to develop guidance and specifications for controlling static electricity in potentially explosive atmospheres. As TC 31 is concerned specifically with equipment, TC 101 will also work independently to develop new standards and maintain existing standards for materials and products that do not come under the scope of TC 31, but are nevertheless used in potentially explosive atmospheres. Liaison arrangement with other IEC or ISO TC that have responsibility for specific product standards will be implemented and Joint Working Groups established as necessary.</p> <p>Healthcare Sector</p> <p>TC 101 will systematically review the market needs in the healthcare sector to determine if further publications in IEC 61340 Part 6 need to be developed. This will be done in collaboration with the relevant IEC and ISO TC through existing liaison</p>	New Projects	
	IEC 61340-4-11 Standard test methods for specific applications – Testing of electrostatic properties of composite IBC – Testing within the scope of quality assurance and safety	2022-09
	Revisions	
	IEC TS 60079-32-1 Explosive atmospheres - Part 32-1: Electrostatic hazards, guidance	Revision started 2020-01
	IEC 60079-32-2 Explosive atmospheres - Part 32-2: Electrostatic hazards - Tests	Revision started 2020-01
	IEC 61340-6-1 ED 1: Electrostatic control for healthcare – General requirements for facilities	To be reviewed 2022-06

arrangements.		
Commercial & Domestic Sectors	New Project	
TC 101 has identified an interest in developing guidance for control of hazards and nuisance effects of static electricity in areas such as offices and public places where such controls have not previously existed or have been ignored.	PWI/TS 101-4 Electrostatic control in office areas and public places	Submit TS 2021-12
General applications	Revisions	
	IEC TS 61340-4-2 Electrostatics - Part 4-2: Standard test methods for specific applications - Electrostatic properties of garments	To be reviewed in 2022-06
Review demand for new standards	<p>TC 101 has carried out a review to establish the demand for test method or product standards for materials and products used to control electrostatic nuisance and other phenomena. A number of potential new work items have been identified and TC 101 will continue to discuss these, and at the appropriate time initiate new work items independently or in cooperation with other IEC or ISO TC/SC.</p> <p>One such item is the need for guidance on the avoidance of electrostatic shocks. IEC 60479-2 ED1 has some relevance, but the parameters used to define discharge waveforms are outside of the range of typical ESD. Revision of IEC 60479-2 was started in 2020-03. The first CD for IEC 60479-2 ED2 does include a section on electrostatics. TC 101 will collaborate on this project via the liaison that has been established with TC 64.</p>	Ongoing
Note: The progress on the actions should be reported in the RSMB.		